

## Single Chiller & Cooling Tower w/Pumps

### Detail - Chiller Piping

No Scale

#### Notes:

1. See Floor Plans and Diagrams for Continuation of Piping and Related Pipe Sizes.
2. Provide Vibration Isolation Pads Between the Chiller and the Housekeeping Pad per Specifications.
3. All Valves and Specialties are Typical Where Shown.
4. Flow Meters (Ultrasonic or Onicon) are Provided by the BAS Contractor and Installed by the Mechanical Contractor. For Installation Requirements for Piping and BAS Connections see Separate Details and Specifications.
5. See Separate Detail for Cooling Tower Piping Requirements.

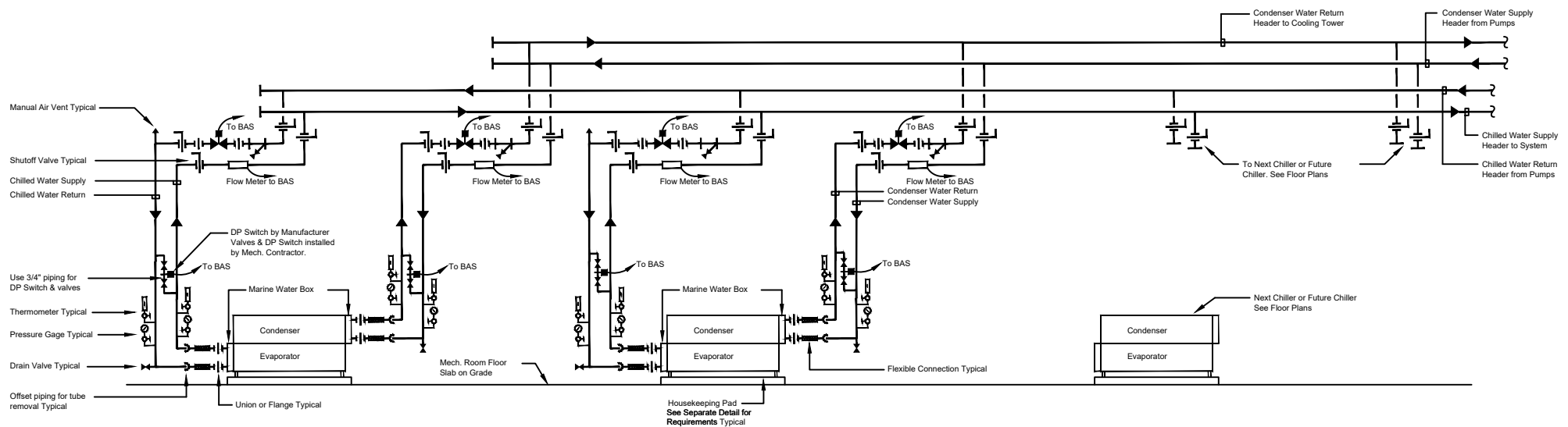

Multiple Chillers & Cooling Towers w/Pumps

**Detail - Multiple Chiller Piping**

No Scale

Notes:

1. See Floor Plans and Diagrams for Continuation of Piping and Related Pipe Sizes.
2. Provide Vibration Isolation Pads Between the Chiller and the Housekeeping Pad per Specifications.
3. All Valves and Specialties are Typical Where Shown.
4. Flow Meters (Ultrasonic or Onicon) are Provided by the BAS Contractor and Installed by the Mechanical Contractor. For Installation Requirements for Piping and BAS Connections see Separate Details and Specifications.
5. See Separate Detail for Cooling Tower Piping Requirements.